

JEE Main January 2025
Question Paper With Text Solution
23 January | Shift-01

PHYSICS



JEE Main & Advanced | XI-XII Foundation | VI-X Pre-Foundation

Office : Piprali Road, Sikar (Raj.) | Ph. 01572-241911
Website : www.matrixedu.in ; Email : smd@matrixacademy.co.in

**JEE MAIN JANUARY 2025 | 23 JANUARY SHIFT-1****SECTION - A**

Question ID : 7364751011

26. A point particle of charge Q is located at P along the axis of an electric dipole 1 at a distance r as shown in the figure. The point P is also on the equatorial plane of a second electric dipole 2 at a distance r . The dipoles are made of opposite charge q separated by a distance $2a$. For the charge particle at P not to experience any net force, which of the following correctly describes the situation?

- (1) $\frac{a}{r} \sim 0.5$ (2) $\frac{a}{r} \sim 10$ (3) $\frac{a}{r} \sim 20$ (4) $\frac{a}{r} \sim 3$

Ans. Official answer NTA (4)

Sol.

Question ID : 7364751006

27. Given below are two statements:

Statement I: The hot water flows faster than cold water

Statement II: Soap water has higher surface tension as compared to fresh water.

In the light above statements, choose the correct answer from the options given below

- (1) Both Statement I and Statement II are true
(2) Statement I is false but Statement II is true
(3) Statement I is true but Statement II is false
(4) Both Statement I and Statement II are false

Ans. Official answer NTA (3)

Sol.

Question ID : 7364751002

28. The electric flux is $\phi = \alpha\sigma + \beta\lambda$ where λ and σ are linear and surface charge density, respectively.

$\left(\frac{\alpha}{\beta}\right)$ represents

- (1) area (2) charge (3) displacement (4) electric field

Ans. Official answer NTA (3)

MATRIX JEE ACADEMY

Office : Piprali Road, Sikar (Raj.) | Ph. 01572-241911

Website : www.matrixedu.in ; Email : smd@matrixacademy.co.in

**Sol.**

Question ID : 7364751017

29. A spherical surface of radius of curvature R , separates air from glass (refractive index = 1.5). The centre of curvature is in the glass medium. A point object O placed in air on the optic axis of the surface, so that its real image is formed at I inside glass. The line OI intersects the spherical surface at P and $PO = PI$. The distance PO equals to

- (1) $1.5R$ (2) $2R$ (3) $5R$ (4) $3R$

Ans. Official answer NTA (3)**Sol.**

Question ID : 7364751016

30. What is the lateral shift of a ray refracted through a parallel-sided glass slab of thickness ' t ' in terms of the angle of incidence ' i ' and angle of refraction ' r ', if the glass slab is placed in air medium?

- (1) $\frac{t \sin(i-r)}{\cos r}$ (2) t (3) $\frac{t \cos(i-r)}{\sin r}$ (4) $\frac{t \tan(i-r)}{\tan r}$

Ans. Official answer NTA (1)**Sol.**

Question ID : 7364751001

31. The position of a particle moving on x-axis is given by $x(t) = A \sin t + B \cos^2 t + Ct^2 + D$, where t is time. The dimension of $\frac{ABC}{D}$ is

- (1) L^2T^{-2} (2) L^3T^{-2} (3) L (4) L^2

Ans. Official answer NTA (1)**Sol.**

Question ID 7364751009

32. A light hollow cube of side length 10 cm and mass 10 g, is floating in water. It is pushed down and released to execute simple harmonic oscillations. The time period of oscillations is $y\pi \times 10^{-2} s$, where the value of y is (Acceleration due to gravity, $g = 10m/s^2$, density of water = $10^3 kg/m^3$)

- (1) 4 (2) 2 (3) 1 (4) 6

Ans. Official answer NTA (2)**Sol.**



Question ID : 7364751003

33. A solid sphere of mass 'm' and radius 'r' is allowed to roll without slipping from the highest point of an inclined plane of length 'L' and makes an angle 30° with the horizontal. The speed of the particle at the bottom of the plane is v_1 . If the angle of inclination is increased to 45° while keeping L constant. Then the new speed of the sphere at the bottom of the plane is v_2 . The ratio $v_1^2 : v_2^2$ is

- (1) 1:3 (2) $1:\sqrt{2}$ (3) $1:\sqrt{3}$ (4) 1:2

Ans. Official answer NTA (2)**Sol.**

Question ID 7364751014

34. The electric field of an electromagnetic wave in free space is

$$\vec{E} = 57 \cos [7.5 \times 10^6 t - 5 \times 10^{-3} (3x + 4y)] (4\hat{i} - 3\hat{j}) \text{ N/C}$$

The associated magnetic field in Tesla is

(1) $\vec{B} = -\frac{57}{3 \times 10^8} \cos [7.5 \times 10^6 t - 5 \times 10^{-3} (3x + 4y)] (5\hat{k})$

(2) $\vec{B} = \frac{57}{3 \times 10^8} \cos [7.5 \times 10^6 t - 5 \times 10^{-3} (3x + 4y)] (\hat{k})$

(3) $\vec{B} = \frac{57}{3 \times 10^8} \cos [7.5 \times 10^6 t - 5 \times 10^{-3} (3x + 4y)] (5\hat{k})$

(4) $\vec{B} = -\frac{57}{3 \times 10^8} \cos [7.5 \times 10^6 t - 5 \times 10^{-3} (3x + 4y)] (\hat{k})$

Ans. Official answer NTA (1)**Sol.**

Question ID : 7364751020

35. Refer to the circuit diagram given in the figure. which of the following observations are correct?

- A. Total resistance of circuit is 6Ω
 B. Current in Ammeter is 1 A
 C. Potential across AB is 4 Volts.
 D. Potential across CD is 4 Volts
 E. Total resistance of the circuit is 8Ω .

Choose the correct answer from the options given below:

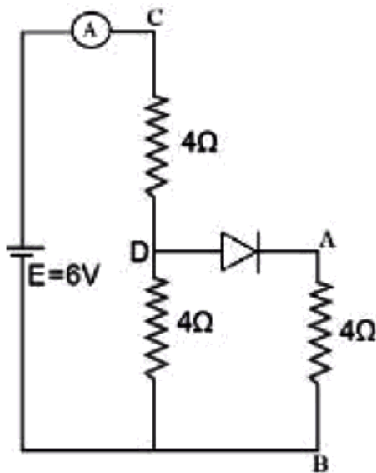

- (1) A, B and D Only (2) A, C and D Only (3) B, C and E Only (4) A, B and C Only

Ans.

Ans. Official answer NTA (1)

Question ID : 7364751005

36. Consider a circular disc of radius 20 cm with centre located at the origin. A circular hole of radius 5 cm is cut from this disc in such a way that the edge of the hole touches the edge of the disc. The distance of centre of mass of residual or remaining disc from the origin will be

- (1) 2.0 cm (2) 1.0 cm (3) 0.5 cm (4) 1.5 cm

Ans. Official answer NTA (2)

Sol.

Question ID : 7364751008

37. Match the LIST-I with LIST-II

LIST-I

- A. Pressure varies inversely with volume of an ideal gas.
 B. Heat absorbed goes partly to increase internal energy and partly to do work.
 C. Heat is neither absorbed nor released by a system.
 D. No work is done on or by a gas.

LIST-II

- I. Adiabatic process
 II. Isochoric process
 III. Isothermal process
 IV. Isobaric process

Choose the correct answer from the options given below:

- (1) A-I, B-IV, C-II, D-III (2) A-I, B-III, C-II, D-IV

MATRIX JEE ACADEMY

Office : Piprali Road, Sikar (Raj.) | Ph. 01572-241911

Website : www.matrixedu.in ; Email : smd@matrixacademy.co.in



(3) A-III, B-I, C-IV, D-II

(4) A-III, B-IV, C-I, D-II

Ans. Official answer NTA (4)**Sol.**

Question ID : 7364751018

38. A sub-atomic particle of mass 10^{-30} kg is moving with a velocity 2.21×10^6 m/s. Under the matter wave consideration, the particle will behave closely like _____. ($h = 6.63 \times 10^{-34}$ J.s)

(1) Visible radiation (2) X-rays (3) Gamma rays (4) Infra-red radiation

Ans. Official answer NTA (2)**Sol.**

Question ID : 7364751019

39. A radioactive nucleus n_2 has 3 times the decay constant as compared to the decay constant of another radioactive nucleus n_1 . If initial number of both nuclei are the same, what is the ratio of number of nuclei of n_2 to the number of nuclei of n_1 , after one half-life of n_1 ?

(1) 1/8 (2) 8 (3) 1/4 (4) 4

Ans. Official answer NTA (3)**Sol.**

Question ID : 7364751015

40. Given a thin convex lens (refractive index μ_2), kept in a liquid (refractive index $\mu_1, \mu_1 < \mu_2$) having radii of curvatures $|R_1|$ and $|R_2|$. Its second surface is silver polished. Where should an object be placed on the optic axis so that a real and inverted image is formed at the same place?

(1)
$$\frac{\mu_1 |R_1| \cdot |R_2|}{\mu_2 (|R_1| + |R_2|) - \mu_1 |R_2|}$$

(2)
$$\frac{\mu_1 |R_1| \cdot |R_2|}{\mu_2 (2|R_1| + |R_2|) - \mu_1 \sqrt{|R_1| \cdot |R_2|}}$$

(3)
$$\frac{\mu_1 |R_1| \cdot |R_2|}{\mu_2 (|R_1| + |R_2|) - \mu_1 |R_1|}$$

(4)
$$\frac{(\mu_2 + \mu_1) |R_1|}{(\mu_2 - \mu_1)}$$

Ans. Official answer NTA (1)**Sol.**

Question ID : 7364751007



41. A gun fires a lead bullet of temperature 300 K into a wooden block. The bullet having melting temperature of 600 K penetrates into the block and melts down. If the total heat required for the process is 625 J, then the mass of the bullet is ____ grams. (Latent heat of fusion of lead = $2.5 \times 10^4 \text{ JKg}^{-1}$ and specific heat capacity of lead = $125 \text{ JKg}^{-1}\text{K}^{-1}$)

- (1) 20 (2) 10 (3) 15 (4) 5

Ans. Official answer NTA (2)

Sol.

Question ID : 7364751012

42. Regarding self-inductance:

- A. The self-inductance of the coil depends on its geometry.
- B. Self-inductance does not depend on the permeability of the medium.
- C. Self-induced e.m.f. opposes any change in the current in a circuit.
- D. Self-inductance is electromagnetic analogue of mass in mechanics.
- E. Work needs to be done against self-induced e.m.f. in establishing the current.

Choose the correct answer from the options given below:

- (1) A, B, C, E only (2) A, B, C, D only (3) B, C, D, E only (4) B, C, D, E only

Ans. Official answer NTA (4)

Sol.

Question ID : 7364751004

43. The motion of an airplane is represented by velocity-time graph as shown below. The distance covered by airplane in the first 30.5 second is ____ km.

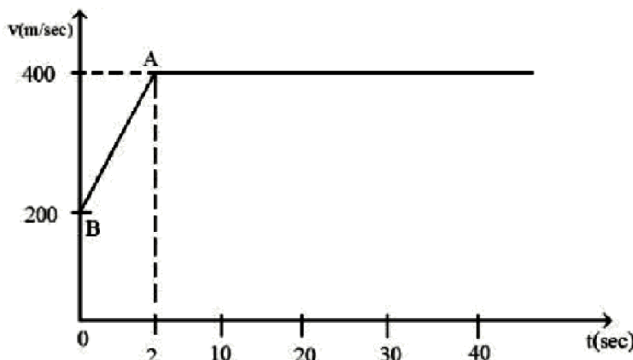

- (1) 12 (2) 3 (3) 9 (4) 6

Ans. Official answer NTA (1)

**Sol.**

Question ID : 7364751010

44. Identify the valid statements relevant to the given circuit at the instant when the key is closed.

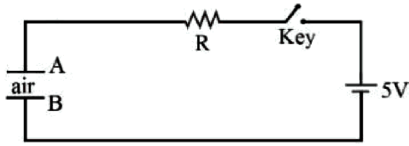

- A. There will be no current through resistor R.
- B. There will be maximum current in the connecting wires.
- C. Potential difference between the capacitor plates A and B is minimum.
- D. Charge on the capacitor plates is minimum.

Choose the correct answer from the options given below:

- (1) B, C, D Only (2) C, D Only (3) A, B, D Only (4) A, C Only

Ans. Official answer NTA (1)**Sol.**

Question ID : 7364751013

45. Consider a moving coil galvanometer (MCG):

- A. The torsional constant in moving coil galvanometer has dimensions $[ML^{-2} T^{-2}]$
- B. Increasing the current sensitivity may not necessarily increase the voltage sensitivity.
- C. If we increase number of turns (N) to its double (2N), then the voltage sensitivity doubles.
- D. MCG can be converted into an ammeter by introducing a shunt resistance of large value in parallel with galvanometer.
- E. Current sensitivity of MCG depends inversely on number of turns of coil.

Choose the correct answer from the options given below:

- (1) A, D Only (2) A, B Only (3) B, D, E Only (4) A, B, E Only

Ans. Official answer NTA (2)**Sol.**



Question ID : 7364751022

46. A force $\mathbf{f} = x^2y\hat{i} + y^2\hat{j}$ acts on a particle in a plane $x + y = 10$. The work done by this force during a displacement from (0, 0) to (4 m, 2m) is _____ Joule (round off to the nearest integer)

Ans. Official answer NTA (152)**Sol.**

Question ID : 7364751024

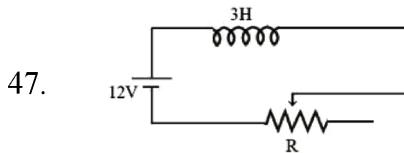

In the given circuit the sliding contact is pulled outwards such that electric current in the circuit changes at the rate of 8 A/s. At an instant when R is 12Ω , the value of the current in the circuit will be ___ A. **Ans.**

Official answer NTA (3)

Sol.

Question ID : 7364751023

48. An ideal gas initially at 0°C temperature, is compressed suddenly to one fourth of its volume. If the ratio of specific heat at constant pressure to that at constant volume is $3/2$, the change in temperature due to the thermodynamic process is _____ K.

Ans. Official answer NTA (273)**Sol.**

Question ID : 7364751025

49. A positive ion A and a negative ion B has charges $6.67 \times 10^{-19}\text{ C}$ and $9.6 \times 10^{-10}\text{ C}$, and masses $19.2 \times 10^{-27}\text{ kg}$ and $9 \times 10^{-27}\text{ kg}$ respectively. At an instant, the ions are separated by a certain distance r. At that instant the ratio of the magnitudes of electrostatic force to gravitational force is $P \times 10^{-13}$, where the value of P is _____ .

(Take $\frac{1}{4\pi\epsilon_0} = 9 \times 10^9\text{ Nm}^2\text{C}^{-1}$ and universal gravitational constant as $6.6 \times 10^{-11}\text{ N m}^2\text{kg}^{-2}$)

Ans. Official answer NTA (D)

Matrix answer NTA (Bonus)

Sol.



Question ID :7364751021

50. Two particles are located at equal distance from origin. The position vectors of those are represented by $\vec{A} = 2\hat{i} + 3n\hat{j} + 2\hat{k}$ and $\vec{B} = 2\hat{i} - 2\hat{j} + 4p\hat{k}$, respectively. If both the vectors are at right angle to each other, the value of n^{-1} is_____.

Ans. Official answer NTA (3)

Sol.

